

**Grading along Platted Subdivision  
Adjacent to Unimproved Thoroughfare  
(Cut Section)**

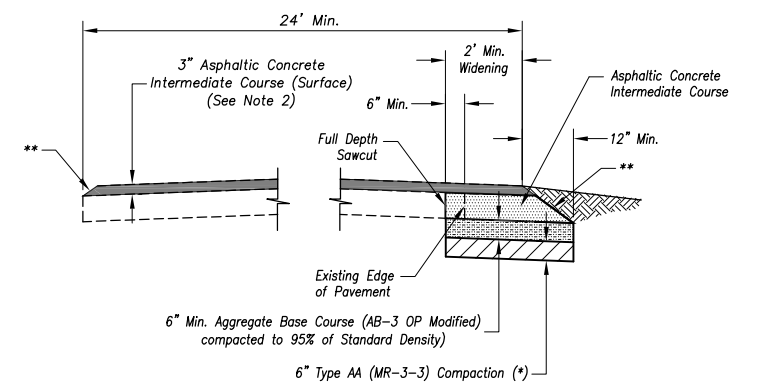

\* - 12" Type AA (MR-3-3) Compaction on top of Type B (MR-90) Compaction in Fill Sections.  
\*\* - Roll or form edge of pavement at 2:1 slope (Typ.)

**Detail 1**  
Not to Scale

**Notes:**

- Overland Park Municipal Code (OPMC) and Overland Park Design and Construction Standards Manual (OPDCSM) are incorporated, except as otherwise noted.
- In accordance with OPMC Chapter 18.460.260, if the existing pavement is irregular, excessively deteriorated, constructed of material other than asphaltic concrete, or the asphalt is less than 3 inches thick, then the entire street section shall be overlaid with 3 inches of Asphaltic Concrete Intermediate Course (Surface). Overlay thickness of less than 3 inches may be installed as determined by the City Engineer.
- If the existing pavement section is less than 22 feet in width, the pavement shall be widened to a minimum width of 24 feet. Additional thickness shall be applied as necessary to create a cross slope of 2%.
- Any cross road pipes, driveway or street culverts, and other clear zone obstructions on the widened side of the roadway shall be modified as necessary to meet the requirements of the AASHTO Roadside Design Guide. If this is not practical, installation of guardrails may be required as determined by the City Engineer.
- Shoulders for the widened section shall match the existing shoulder materials within the project limits.
- Ditch sections shall be designed to carry the 10-year design flow.
- The contractor shall sod all disturbed areas within the public street Right-of-Way adjacent to developed property. The contractor shall sod or seed and mulch all disturbed areas within or outside of the public street Right-of-Way adjacent to undeveloped property.

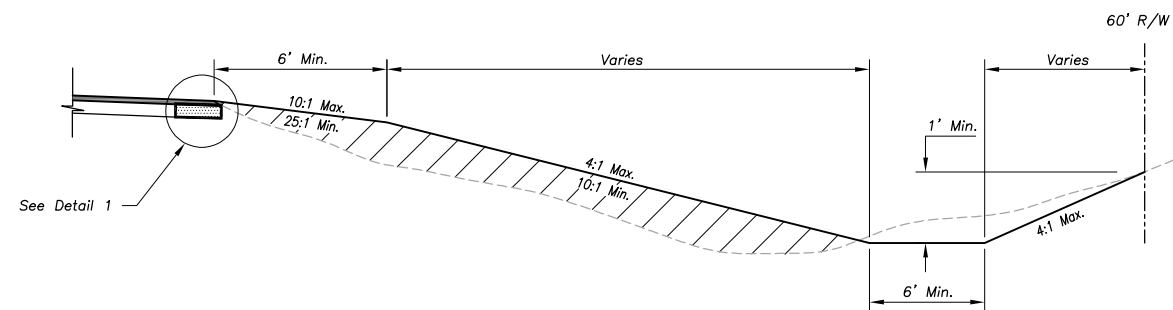

**Fill Section  
Shoulder Improvements**  
Not to Scale

Year 2019 Edition

REVISIONS:	
Feb. 2008	OPMC Reference
RELATED ORDINANCES:	
OPMC Title 13	
OPMC Title 18	

**OVERLAND PARK**  
KANSAS

ABOVE AND BEYOND. BY DESIGN.

DEPARTMENT OF PUBLIC WORKS  
STANDARD DETAILS

UNIMPROVED THOROUGHFARE MODIFICATION