

\* - Brick Pavers shall meet the requirements of ASTM C1272, Type F, Application PX.  
 \*\* - Edge Underdrain can be used

**Section A-A**  
 Not to Scale

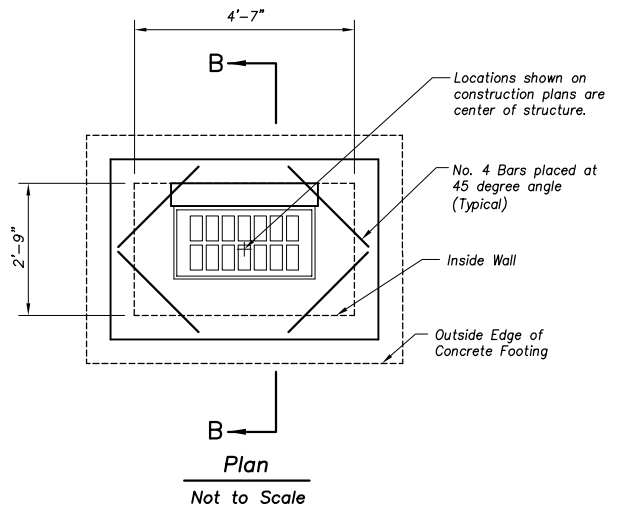

**Plan**  
 Not to Scale

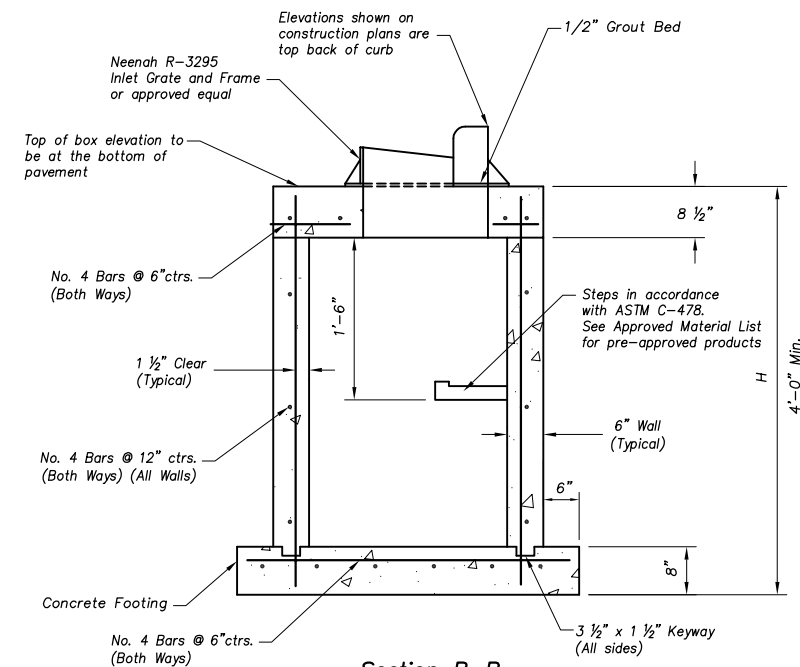

**Section B-B**  
 Not to Scale

**GRATE INLET**

Not for General Use  
 Use only with approval of City Engineer

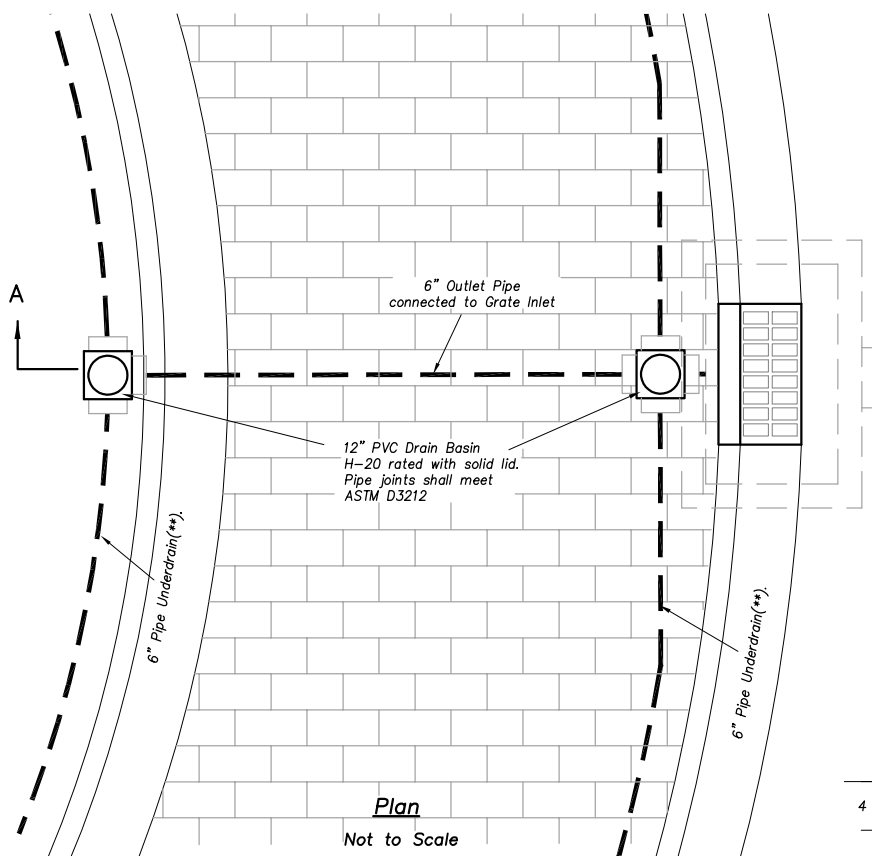

**Plan**  
 Not to Scale

**TRUCK APRON WITH GRATE INLET**

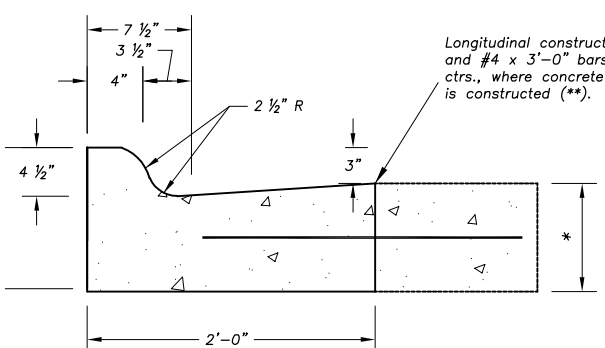

**Wet Curb**

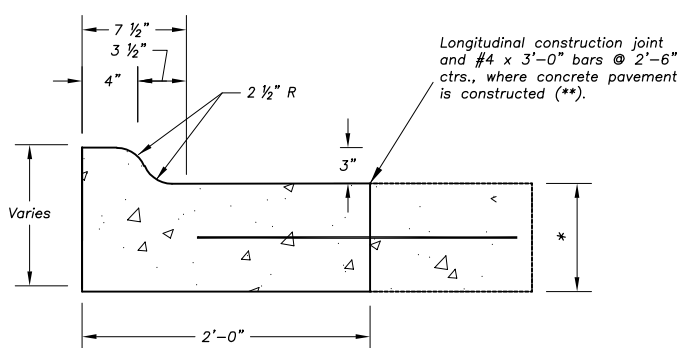

**Dry Curb**

**Type B Curb and Gutter (Special)**

\* - Thickness to match adjacent pavement.  
 \*\* - If constructed monolithically, the longitudinal joint is not required.

**Grate Inlet Notes:**

**General**

1. The Overland Park Municipal Code (OPMC) and Overland Park Design and Construction Standards Manual (OPDCSM) are incorporated, except as otherwise noted.
2. Do not scale these drawings for dimensions or clearances. Any questions regarding dimensions shall be brought to the attention of the City Engineer prior to construction.
3. On-grade inlets shall conform to the street grade and sump inlets shall be level.
4. The first dimension listed in the construction notes is the "L" dimension. The second dimension is the "W" dimension. The concrete thickness and reinforcement shown is for boxes with ("L"+"H") and ("W"+"H") less than or equal to 20. For boxes with either of these calculations greater than 20, a special design is required.

**Concrete**

5. Concrete used in this work shall be KCMMB4K, as approved by the Johnson County Concrete Board, and shall meet the requirements of the Overland Park Municipal Code.
6. Concrete construction shall meet the applicable requirements of Standard Specifications for State Road and Bridge Construction, Kansas Department of Transportation, latest edition, except as modified in the Overland Park Municipal Code.
7. Inlet floors shall be shaped with non-reinforced concrete inverts to provide smooth flow.
8. Bevel all exposed edges with 3/4" triangular molding.

**Reinforcing Steel**

9. Reinforcing steel shall be new billet, minimum Grade 60 as per ASTM A615M, and shall be bent cold.
10. All dimensions relative to reinforcing steel are to centerline of bars. 2" clearance shall be provided throughout unless noted otherwise. Tolerance of +/- 1/8" shall be permitted.
11. All lap splices not shown shall be a minimum of 40 bar diameters in length.
12. All reinforcing steel shall be supported on fabricated steel bar supports @ 3'-0" maximum spacing.
13. All dowels shall be accurately placed and securely tied in place prior to placement of bottom slab concrete. Sticking of dowels into fresh or partially hardened concrete will not be acceptable.

**Construction**

14. The bottom slab shall be at least 24 hours old before placing sidewall concrete. All sidewall forms shall remain in place a minimum of 24 hours after sidewalls are poured before removal, and after removal shall be immediately treated with membrane curing compound.
15. Grate inlet top to be constructed after final curb string line has been approved by the Engineer and prior to curb construction, or as directed by the City Engineer.
16. Pipe connections to pre-cast structures shall have a minimum of 6" of concrete around the entire pipe within 2' of the outside wall of structure. A minimum of 2" - maximum of 6" clearance is required between the outside pipe wall and the edge of blackout.
17. Geotextile fabric shall be placed over contraction joints in concrete pavement and curb to keep sand on place.
18. Removable Flowable Fill is required under any portion of paved right of way, including the area within existing or future public street pavement and under existing or future curb and gutter, median, asphalt path, concrete sidewalk.
19. Material selection and compaction requirements for backfill around structures shall be as specified in the Manual of Infrastructure Standards, as promulgated by the City Engineer.

REVISIONS:	
RELATED ORDINANCES:	
	OPMC Title 13;
	OPMC Title 15;

Year 2019 Edition

**OVERLAND PARK**  
 KANSAS  
 ABOVE AND BEYOND. BY DESIGN.

DEPARTMENT OF PUBLIC WORKS  
 STANDARD DETAILS

**ROUNDAABOUT DETAILS**